

EnergoAqua Industry

Water Supplied Radiant Heating



Use the EnergoAqua Industry Radiant Panels for a trouble and maintenance free heating system, offering minimal running costs and an even and comfortable indoor climate. The EnergoAqua Industry is a highly developed product, designed to be economical, safe and comfortable.

EnergoAqua Industry is ideal for use in manufacturing facilities, warehouses, sport and tennis halls or similar applications and is equally suitable for new-builds and refurbishments.

Composition

EnergAqua Industry, EAI, consists of three parts, the reflective plate, insulation and the water carrying pipes. CE marked and manufactured in accordance with EN 14037.

The panel comprises of a 0.9 mm aluminium plate which is cold pressed into optimal shape, the insulation consists of 25 mm thick mineral wool topped with plastic covered paper. The pipes are made from steel with diameter \varnothing 35/32 mm. Maximum working pressure 6 Bar.



Design and Function

The surface plate encapsulates the steel pipes maximising the contact surface leading to a highly efficient radiant panel.

The warm water which circulates through the pipes conducts heat to the surface plate, warming the underside of the panel. The increased temperature of the panel enables radiant heat being emitted to cooler surfaces in the room.



Technical Specification

Width: EAI is available in two different widths 615 mm (2 pipes) or 900 mm (3 pipes).

Length: EAI can be made to any length in 500 mm increments up to 6 m per panel. Several panels can be inter-connected to a maximum length of 125 m.

Connections: Panel connections are \varnothing 35 x 1.5 mm via smooth straight pipe ends.

Inter-connections: A panel run, longer than 6 m, can be made by combining a connection panel and an end panel together with a number of intermediate panels. All panels are jointed by using \varnothing 35 mm press-fittings. Panels can be supplied in different versions to accommodate for serial or parallel connections to manage flow rates and pressure drops.

Suspension: EAI should be installed free hanging from the ceiling using the included hangers.

Further information regarding capacities, pressure drops, flow rates and connection options along with accessories and controls can be obtained from our technical brochure.

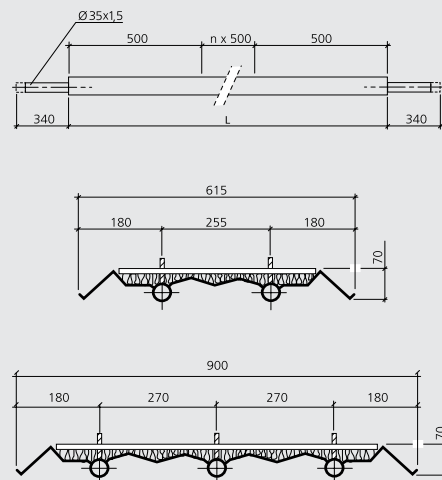

Quick Facts

Heat output:	Up to 500 W/linear meter
Lengths:	Any length in steps of 500 mm up to 6000 mm.
Widths:	615 mm or 900 mm
Installation height:	Up to 30 m
Finish, colour:	NCS3500 / RAL7035 (Grey)
Weight/m excl water:	EAI-2 – 4,5 kg EAI-3 – 7,0 kg
Weight/m incl water:	EAI-2 – 6,1 kg EAI-3 – 9,3 kg

ENERGOTECH